

# AN ONTOGENETIC SEQUENCE OF COCCOLITHS FROM THE LATE JURASSIC KIMMERIDGE CLAY OF ENGLAND

by JEREMY R. YOUNG *and* PAUL R. BOWN

**ABSTRACT.** The Kimmeridge Clay of Kimmeridge Bay, Dorset, UK, includes several stone bands which electron microscopy shows are coccolith limestones dominated by the species *Watznaueria fossacincta*. The assemblage includes not only fully grown coccoliths but also specimens at earlier growth stages, including proto-coccolith rings. A complete ontogenetic sequence can thus be reconstructed. This interpretation is supported by the occurrence of early growth stages inside coccospheres, i.e. intracellular coccoliths preserved in the process of growth. The coccolith formation process appears to have been directly comparable to that known in living coccolithophores. The early growth phases have previously been described as separate species; these can now be put in synonymy.

COCCOLITHS are minute calcareous platelets produced by unicellular planktonic algae of the division Prymnesiophyta. They are borne extracellularly as a coccosphere of several individual coccoliths, but are formed intracellularly, as the product of an elaborate biomineralization process. Studies of this process in living coccolithophores have highlighted the fact that it does not occur by calcification of a pre-existing organic matrix, but rather is a growth process. Typically coccolith growth involves first nucleation of a proto-coccolith ring of simple crystals, then closely regulated growth of these crystals into the complex segments that constitute fully formed coccoliths (Westbroek *et al.* 1984, 1989; Mann and Sparks 1988; van Emburg 1989; Young 1989). Since this is a growth process with distinct developmental stages, individual coccoliths can be considered to have an ontogenetic history. When this concept is contrasted with the alternative of regarding coccoliths as formed objects, it is clear that it can provide an improved framework for the interpretation of coccolith structure, morphological variation, classification and evolution. However, since the concept has been derived from study of a few living species, nannofossil palaeontologists have not been widely convinced of its relevance or applicability. We describe here, for the first time, an ontogenetic sequence of this type in the fossil record, and use it to illustrate the utility of such studies.

## MATERIAL AND PALAEOENVIRONMENT

The Kimmeridge Clay Formation is a thick (*c.* 500 m) organic-rich shale of Late Jurassic age deposited over an extensive area of the NW European shelf including much of the North Sea and southern England. The best known outcrops are in Kimmeridge Bay, Dorset, the stratotype of the Kimmeridgian Stage. A remarkable feature of the formation is the presence of several bands of laminated limestone almost entirely formed of coccospheres and isolated coccoliths of the species *Watznaueria fossacincta* (Downie 1957; Noel 1973; Gallois and Medd 1979). The extensive occurrence of coccospheres, the lamination of the sediment, and the absence of admixed clay are almost certainly the result of rapid deposition in anoxic bottom waters, as also indicated by geochemical and macrofaunal evidence (Myers and Wignall 1987; Oschmann 1988). The domination of the assemblage by a single species is partly a reflection of the low diversity of Late Jurassic nannofloras but is also suggestive of a degree of ecological restriction. The combination of

low diversity, good preservation and abundant coccospheres made these beds attractive for a study of morphological variation within a single species. For this reason a special study was made of coccoliths from one of the best developed limestone bands, the White Stone Band, within the *Pectinatites pectinatus* Zone.

#### ONTOGENETIC SEQUENCE

A typical fracture surface of the White Stone Band is illustrated in Plate 1, fig. 1. This shows abundant coccoliths and coccospheres of the species *Watznaueria fossacincta* (Black, 1971) Bown in Bown and Cooper 1989. Rare specimens of species from a few other genera also occur (*P.m* and *Z.e* on Pl. 1, fig. 1). In addition, several coccoliths with broad central areas and narrow rims are visible (arrows in Pl. 1, fig. 1). These lack the well developed shields of *W. fossacincta* but have structural similarities and have been regarded as separate species of the genus *Watznaueria* (e.g. Grun and Zweili 1980). However, if a series of these forms from the open rings to typical *W. fossacincta* specimens is assembled, it is apparent that there is continuous variation between them. Two such sequences are shown in Plate 1, one in distal view (Pl. 1, figs 3–5) and the other in proximal view (Pl. 1, figs 6–9). The continuity of variation is primary evidence that the variation is intraspecific but the range of morphology is too great for preservational, ecophenotypic or genotypic variation of mature forms. A simple alternative interpretation of this sequence is that it is an ontogenetic growth sequence, and indeed it is closely comparable to growth sequences described from living species such as *Emiliana huxleyi* (Westbroek *et al.* 1984, 1989; van Emburg 1989). Further evidence is provided by the presence of broken coccospheres containing ring-like coccoliths (Pl. 1, figs 2 and 10). The occurrence of these coccoliths inside the coccospheres is unlikely to be coincidental since several examples were seen in the electron microscope, and in the light microscope single coccoliths were also often discernible inside entire coccospheres. For the purposes of comparison, scanning electron micrographs were taken of broken coccospheres of cultured *Emiliana huxleyi* (Pl. 1, figs 11 and 12). The analogy with the fossil specimens is plain. So rather than being a chance association, these ring-like coccoliths occurring within coccospheres are almost certainly examples of fossilized intracellular coccoliths preserved due to death of the cell during the process of coccolith formation. This in turn makes it only reasonable to interpret the series of coccolith morphologies as an ontogenetic sequence of coccolith growth stages.

---

#### EXPLANATION OF PLATE 1

Scanning electron micrographs of *Watznaueria* specimens in the White Stone Band, and comparable specimens of the modern coccolithophore *Emiliana huxleyi*.

Fig. 1. Typical fracture surface showing how rock is almost entirely composed of *Watznaueria* coccoliths, either isolated or in coccospheres. Arrows, incompletely formed coccoliths. Coccoliths of other species: *Z.e.*, *Zeugrhabdotus erectus*; *P.m.*, *Polypodorhabdus madingleyensis*.  $\times 2500$ .

Fig. 2. Broken coccosphere with internal coccolith at early growth stage. The living cell would have occupied the space within the coccosphere, and the incomplete coccolith would have been forming within it.  $\times 6500$ .

Fig. 3. Very early growth stage/proto-coccolith ring, distal view,  $\times 10200$ .

Fig. 4. Mid growth, distal/oblique view,  $\times 11500$ .

Fig. 5. Complete coccolith, distal view,  $\times 6900$ .

Fig. 6. Very early growth/proto-coccolith ring,  $\times 11500$ .

Fig. 7. Early growth, proximal view,  $\times 11500$ .

Fig. 8. Mid growth, proximal view,  $\times 9300$ .

Fig. 9. Complete coccolith, proximal view,  $\times 6900$ .

Fig. 10. Broken coccosphere of *Watznaueria*, with internal proto-coccolith ring. This internal coccolith shows the earliest growth stage observed,  $\times 3200$ .

Fig. 11. Coccosphere of *Emiliana huxleyi*, grown in culture, showing internal proto-coccolith ring,  $\times 6000$ .

Fig. 12. Coccosphere of *E. huxleyi* showing internal coccolith,  $\times 5100$ .

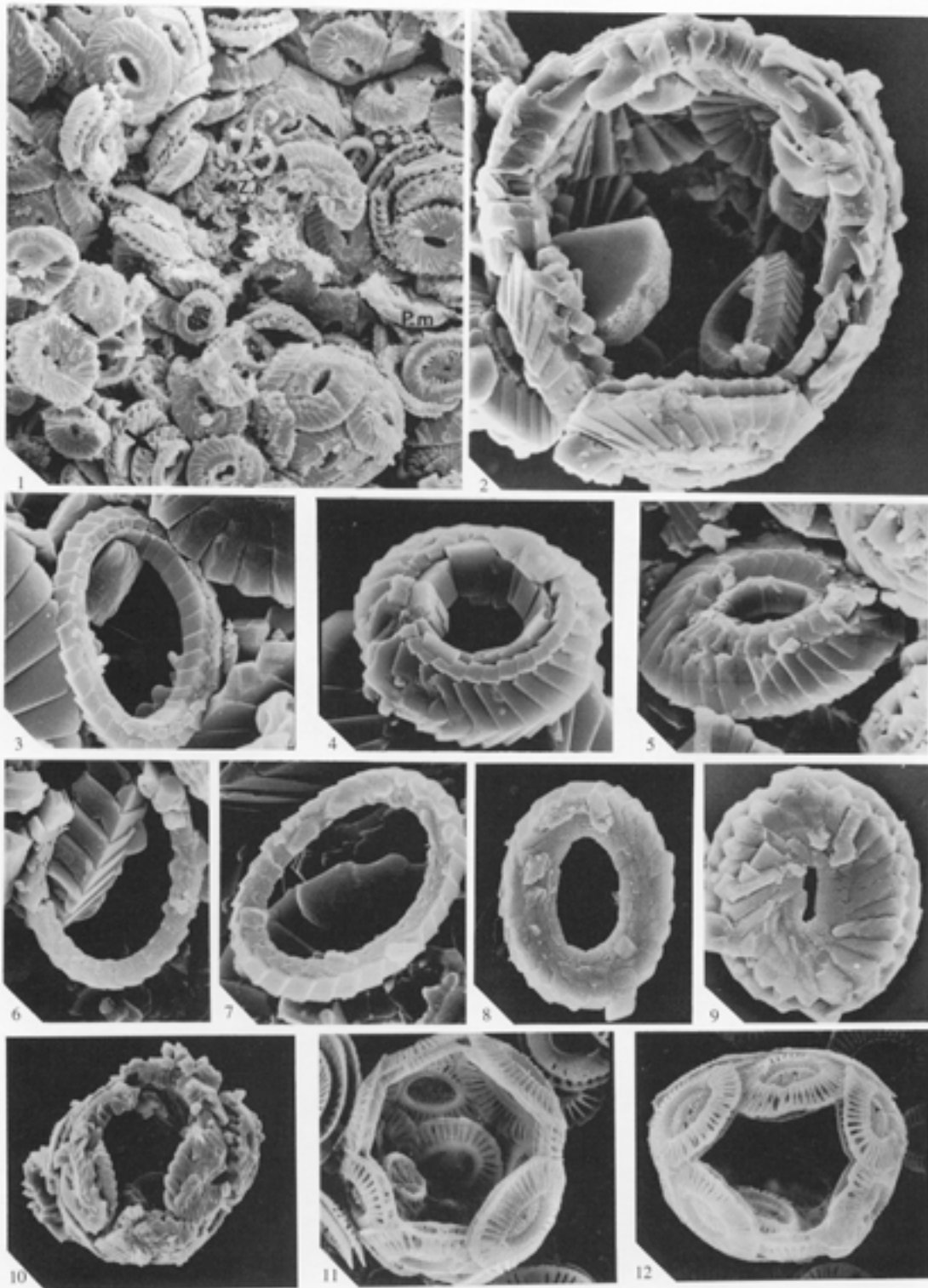

YOUNG and BOWN, *Watznaueria*, *Emiliania*

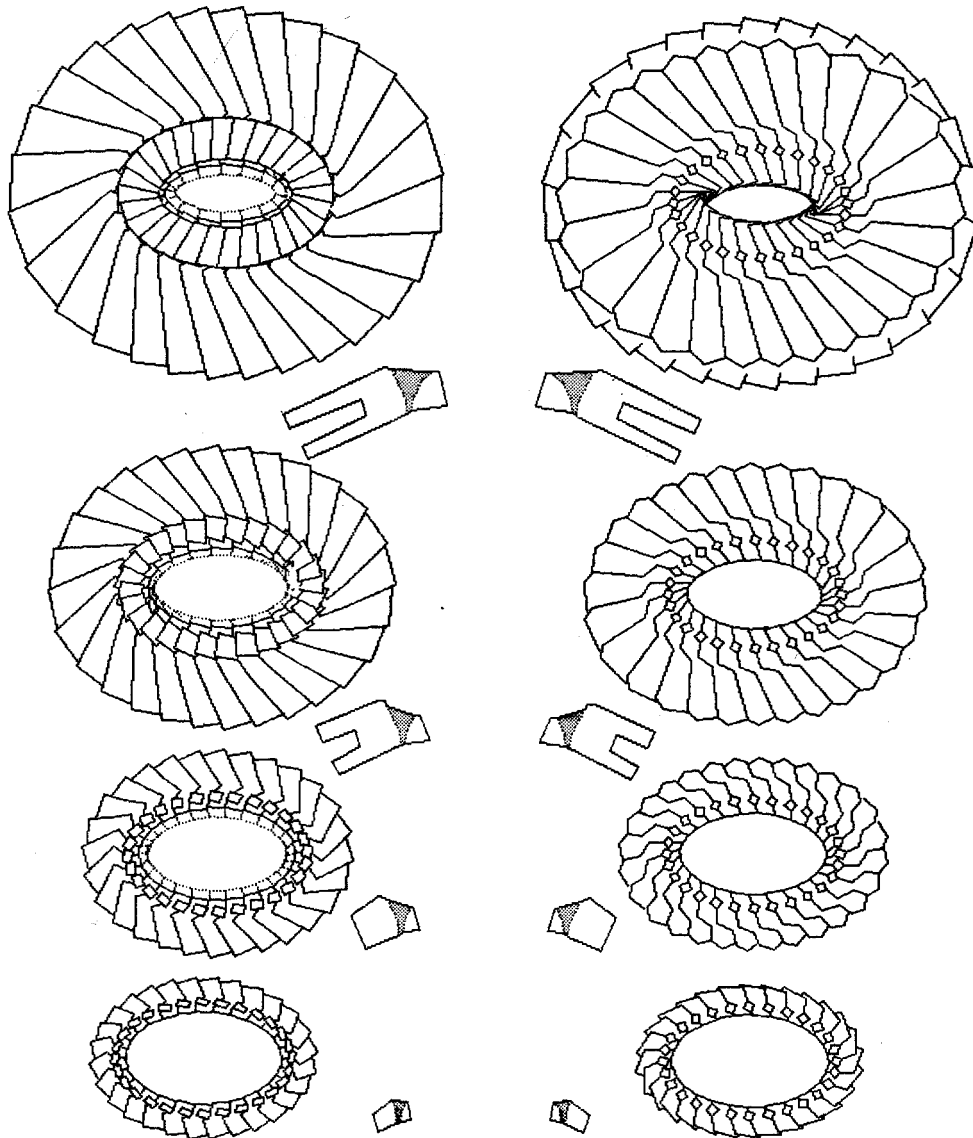

TEXT-FIG. 1. Growth stages of *Watznaueria*, based on a synthesis of observations on many specimens. Each growth stage is illustrated in distal view (left), cross-section (centre) and proximal view (right). Shaded portion of cross-sections is V-unit.

#### STRUCTURAL INTERPRETATION

An interpretative series of diagrams illustrating the growth sequence is given in Text-figure 1. Four growth stages are illustrated, each in proximal view, cross-section, and distal view. Terminology applied to the elements is explained in Text-figure 2. At the earliest observed stage the coccolith consists of an elliptical proto-coccolith ring of sub-quadrangle crystals with intervening very small peg-like crystals. During subsequent growth these two sets of crystal units develop separately. They are referred to as the V- and R-crystal units (Text-fig. 2).

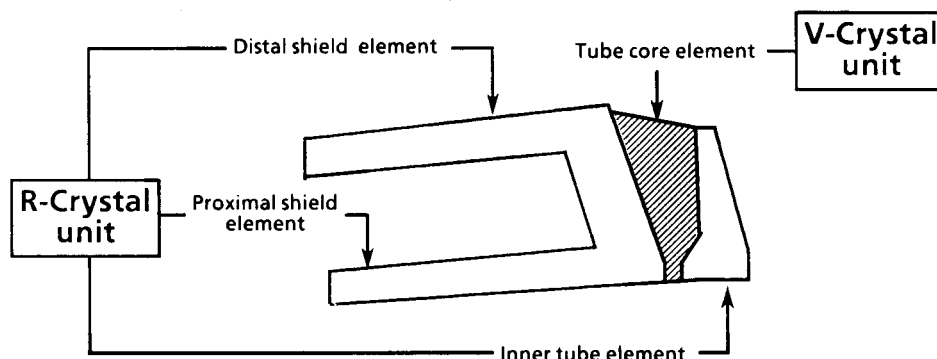

TEXT-FIG. 2. Terminology applied to the crystal units. The V-unit (shaded) has an approximately vertically directed crystallographic c-axis, and so is dark in cross-polarized light in plan view. The R-unit has radially directed c-axis and so is bright in cross-polarized light in plan view.

The larger, initially quadrate, R-crystal units develop into complexly shaped units, composed of several elements, and forming most of the coccolith. The *proximal shield elements* are formed by growth radially outward from the proto-coccolith ring. The elements have a slight initial counter-clockwise kink possibly due to change in growth direction after initial impingement of the crystals (Pl. 1, figs 6–9; Text-fig. 1, left side). The *distal shield elements* show the same kink, clockwise directed in this view, then growth with counter-clockwise precession (Pl. 1, figs 3–5; Text-fig. 1, right side). At the early growth stages the distal shield element directly overlies the proximal shield element, and they are united by a thickened outer tube cycle (Pl. 1, figs 2, 4, 7). Subsequent growth separates the proximal and distal shield elements since there is about a 30° difference in radial growth direction between them.

In proximal view the R-crystal units of the proto-coccolith ring can be seen to grow radially inward as well as outward, closing the central area. These elements also grow upward forming wedge-shaped *inner tube elements* (Pl. 1, figs 3–5; Text-fig. 1, centre).

The interstitial peg-like V-crystal units of the proto-coccolith ring develop upwards only, forming relatively simple crystals, composed of only one element. They outcrop on the distal surface of the complete coccoliths with the appearance of small rectangular plates, but root back to the proximal surface forming a core to the tube, and so are termed here *tube-core elements*.

The R- and V-crystal units remain distinct throughout ontogeny. They also are clearly separated during diagenesis. Under conditions of diagenetic secondary calcification (as in this material) different overgrowth crystal faces develop on the two types of units and there is no sign of them fusing; by contrast the proximal and distal shield elements of the R-crystal unit often do fuse. Under conditions of diagenetic dissolution the V-crystal units are often selectively etched, and may be entirely removed; this morphotype has occasionally been regarded as a separate species *Calolithus martelae* Noel, 1965. The consistent separation of the two crystal units indicates that they are discrete, separately nucleated cycles, presumably with different crystallographic orientations. The crystallographic orientation of the main units is readily determined by light microscope observations, using cross-polarized light and a gypsum plate (as described by Romein 1979). The c-axis is orientated along the length of the proximal shield elements, and so parallel to the base of the coccolith. This is also reflected in the prismatic overgrowths on these elements and in their termination by a zone of crystal faces (Pl. 1, figs 2 and 9). The optical orientation of the V-crystals is less easily determined, but careful light microscope observation of side views suggests the c-axes are directed approximately perpendicular to the base of the coccolith, i.e. at 90° to the c-axes of the main units. In plan view this is indicated by the tube-core cycle appearing as a dark ring in cross-polarized light.

## COMPARISON WITH LIVING SPECIES

Information on coccolith growth is available for a number of living species. Comparison of these species suggests that all the heterococcolith rims show a similar pattern of development (Young 1989; Westbroek *et al.* 1989). Holococcoliths and the central area structures of some heterococcoliths appear to develop in different ways, but *Watznaueria* coccoliths are straightforward heterococcoliths, and so should be directly comparable with the living species. The principal points of similarity between coccolith formation in the living species and their applicability to *Watznaueria* are as follows:

1. Calcification is intracellular (Pl. 1, figs 11 and 12). In *W. fossacincta* the partially formed coccoliths inside coccospheres are striking evidence of this (Pl. 1, figs 2 and 10).
2. Nucleation occurs as a single event – around the rim of an organic base-plate producing a proto-coccolith ring of simple crystals. Proto-coccolith rings are figured here for *W. fossacincta* (Pl. 1, figs 1, 3, 6, and 10). The original presence of an organic base-plate can only be inferred.
3. Crystal growth proceeds upward and laterally from the proto-coccolith ring so that it remains on the proximal surface of the coccolith. This is precisely the pattern of growth seen here.
4. All the crystal units of a single cycle develop according to a single plan, although in some cases to differing degree. *Watznaueria* is a typical coccolith in this respect.
5. Individual crystal units are of complex form but there are rather few separate sets of crystal units. *W. fossacincta* is a fine example of this; superficial examination might suggest that the various cycles of elements were all discrete crystallites but in fact most of them unite, to form the R-crystal units, leaving only the V-crystals separate – as shown here and argued earlier (Bown 1987).

The most distinctive feature of the *Watznaueria* structure is the double proto-coccolith ring and development of a tube-core cycle. This does not have an obvious analogue in the coccoliths of the best studied species, *Emiliana huxleyi*, but does in several other species, for instance *Coccolithus pelagicus* (Young 1989; Steinmetz and Young unpublished data) and *Pleurochrysis carterae* (Outka and Williams 1971). Thus the morphological development of this Mesozoic coccolith was directly comparable to that of living species, and there is no reason to believe that qualitatively different biochemical processes were involved.

## TAXONOMIC IMPLICATIONS

The most immediate application of these observations is that they allow a simplification of Mesozoic nannofossil taxonomy. A number of species of *Watznaueria*/*Ellipsagelosphaera* (a subjective junior synonym) have been proposed based on the degree of opening of the central area and on shield width. On the basis of the growth sequence worked out here, these forms can be seen to be simply growth stages. They include: *E. strigosa* Grun and Zweili, 1980 – proto-coccolith ring; *E. tubulata* Grun and Zweili, 1980 – early growth stage; and *W. ovata* Bukry, 1969 – late growth stage.

Complications are introduced by the presence of forms with a disjunct bridge in the central area (*W. britannica*, and its growth stages *W. lucasii* and *W. reinhardtii*) and by an evolutionary trend toward forms with entirely closed central areas (*W. barnesae*). With the clarification of the structure provided by understanding the growth sequence, and the resultant reduction in number of taxa it should, however, be possible to deal with the genus as a coherent lineage. This in turn should allow meaningful description of its evolutionary development and allow the definition of biostratigraphically useful trends. This would be a considerable contribution to Mesozoic nannofossil biostratigraphy since *Watznaueria* species are the most common component of nannofossil assemblages from the Upper Jurassic to the end Cretaceous plankton extinctions.

Our observations are also significant for higher taxonomy and the relationships between nannofossil families. Rim structure has long been recognised as a primary criterion of higher classification (e.g. Perch-Nielsen 1971; Romein 1979; Bown 1987). However, without a clear understanding of how rim structures develop during ontogeny, their description and interpretation

has been confused. The growth model provides such a framework, and highlights the importance of identifying crystal unit cycles and their crystallographic orientation. In this specific case the identification of a double proto-coccolith ring and determination that the tube cycle has a quite different optical orientation to that of the main units permits a number of hypotheses as to the relationships of Mesozoic coccoliths to be made. These are currently the subject of active investigation.

#### PALAEOECOLOGICAL SIGNIFICANCE

Incomplete coccolith morphotypes have not been widely reported from the fossil record, even when they have been described as separate species. Probably this is mainly because they are somewhat inconspicuous in the light microscope or easily dismissed as preservational artefacts. If they are specifically looked for they can be found in most coccolith assemblages. Nonetheless their abundance in the White Stone Band does seem unusually high, for either fossil or living coccolith assemblages. Culture work on the living species *Emiliana huxleyi* provides one possible interpretation. Incomplete coccoliths are most common in samples from the logarithmic growth phase of cultures grown in high nutrient media (Young unpublished data). An ecological analogue for this situation might be bloom conditions. Such conditions have been independently suggested for the *pectinatus* Zone of the Kimmeridge Clay, in order to explain the coincidence of high productivity, monospecific assemblages and anoxic conditions (Gallois 1976). Possibly the high occurrence of early growth stages may constitute a useful indicator of blooms.

#### CONCLUSION

Evidently coccolithogenesis occurred in the Jurassic by processes very similar to those acting today. In consequence information on the process derived from study of living coccolithophores can be applied to the study of fossil coccoliths. This can have useful applications in understanding taxonomy and evolution, and possibly in making palaeoecological interpretations. More generally it helps provide a palaeobiological perspective to coccolith research, which has been rather dominated by biostratigraphy. Also, understanding the ontogenetic growth of coccoliths allows the application of basic evolutionary concepts such as heterochrony to coccoliths. Since coccoliths have one of the best fossil records of any group this should enrich evolutionary studies as well as coccolithophore research.

*Acknowledgements.* This work was carried out during the tenureship of post-doctoral research fellowships funded by Clyde Petroleum (J. R. Y.), and the Natural Environment Research Council (P. R. B). The electron microscopy unit of The Natural History Museum are thanked for their assistance and expertise. Andy Gale, Dave Ward, and Marigold White provided invaluable support at various stages. Paul Taylor, Dave Watkins, and an anonymous referee made useful comments on the manuscript.

#### REFERENCES

- BLACK, M. 1971. Coccoliths of the Speeton Clay and Sutterby Marl. *Proceedings of the Yorkshire Geological Society*, **38**, 381–424.
- BOWN, P. R. 1987. Taxonomy, evolution and biostratigraphy of Late Triassic–Early Jurassic calcareous nannofossils. *Special Papers in Palaeontology*, **38**, 1–118.
- and COOPER, M. K. E. 1989. New calcareous nannofossil taxa from the Jurassic. *Journal of Micropalaeontology*, **8**, 91–96.
- BUKRY, D. 1969. Upper Cretaceous coccoliths from Texas and Europe. *University of Kansas Paleontological Contributions, Article*, **51**, 1–79.
- DOWNIE, C. 1957. Microplankton from the Kimmeridge Clay. *Quarterly Journal of the Geological Society of London*, **112**, 413–434.

- EMBURG, P. R. VAN 1989. Coccolith formation in *Emiliana huxleyi*. Unpublished Ph.D. thesis, University of Leiden Geobiochemistry Unit.
- GALLOIS, R. W. 1976. Coccolith blooms in the Kimmeridge Clay and origin of North Sea oil. *Nature*, **259**, 473–475.
- and MEDD, A. W. 1979. Coccolith-rich marker bands in the English Kimmeridge Clay. *Geological Magazine*, **116**, 247–260.
- GRUN, W. and ZWEILL, F. 1980. Das kalkige Nannoplankton der Dogger-Malm-Grenze im Berner Jura bei Liesberg (Schweiz). *Jahrbuch der Geologischen Bundesanstalt Wien*, **123**, 231–341.
- MANN, S. and SPARKS, N. H. C. 1988. Single crystalline nature of coccolith elements of the marine alga *Emiliana huxleyi* as determined by electron diffraction and high resolution transmission electron microscopy. *Proceedings of the Royal Society of London, Series B*, **234**, 441–453.
- MYERS, K. J. and WIGNALL, P. B. 1987. Understanding Jurassic organic-rich mudrocks – new concepts using gamma-ray spectrometry and palaeoecology. Examples from the Kimmeridge Clay of Dorset and the Jet Rock of Yorkshire. 172–189. In LEGGETT, J. K. and ZUFFA, G. G. (eds). *Marine clastic sedimentology concepts and case studies*. Graham and Trotman, London, 209 pp.
- NOEL, D. 1965. *Coccolithes Jurassiques*. Centre National de la Recherche Scientifique, Paris, 209 pp.
- 1973. Nannofossiles calcaires de sédiments jurassiques finement laminés. *Bulletin du Muséum National d'Histoire Naturelle* (3), **75**, 95–155.
- OSCHMANN, W. 1988. Kimmeridge Clay sedimentation – a new cyclic model. *Palaeogeography, Palaeoclimatology, Palaeoecology*, **65**, 217–251.
- OUTKA, D. E. and WILLIAMS, D. C. 1971. Sequential coccolith morphogenesis in *Hymenomonas carterae*. *Journal of Protozoology*, **18**, 285–297.
- PERCH-NIELSEN, K. 1971. Dursicht tertiarer coccolithen. 939–980. In FARINACCI, A. (ed.). *Proceedings Second Planktonic Conference, Roma 1970*, **2**, 1–1369.
- ROMEIN, A. J. T. 1979. Lineages in early Palaeogene calcareous nannoplankton. *Utrecht Micropalaeontological Bulletins*, **22**, 1–231.
- WESTBROEK, P., VAN DER WAL, P., BORMAN, A. H., DE VRIND, J. P. M., KOK, D., DE BRUIJN, W. C. and PARKER, S. B. 1984. Mechanism of calcification in the marine alga *Emiliana huxleyi*. *Philosophical Transactions of the Royal Society of London, Series B*, **304**, 435–444.
- YOUNG, J. R. and LINSCHOOTEN, P. 1989. Coccolith production (biomineralisation) in the marine alga *Emiliana huxleyi*. *Journal of Protozoology*, **36**, 368–373.
- YOUNG, J. R. 1989. Observations on heterococcolith rim structure and its relationship to developmental processes. 1–20. In CRUX, J. A. and VAN HECK, S. E. (eds). *Nannofossils and their applications*. Ellis Horwood, Chichester, 356 pp.

JEREMY R. YOUNG

Department of Palaeontology  
The Natural History Museum  
Cromwell Road, London SW7 5BD

PAUL R. BOWN

Department of Geological Sciences  
University College London  
London WC1E 6BT

Typescript received 8 June 1990

Revised typescript received 28 September 1990